

## GWST-MGBS Multi Grip Splined Blind Rivet Nut Stud

Steel · Large flange · Splined · Multi-grip  
M6 - M8

### Features

- Blind rivet nut studs offer a technical as well as cost effective alternative to weld studs
- Dual function - joins material and provides additional fastening point via the threaded stud
- Multi-grip capability accommodates wide variations in material thickness
- Knurling for increased anti-twist protection
- High load bearing capacity of thread
- No damage to painted surfaces
- Suitable for repairing welding studs

### Material

- Steel, galvanised

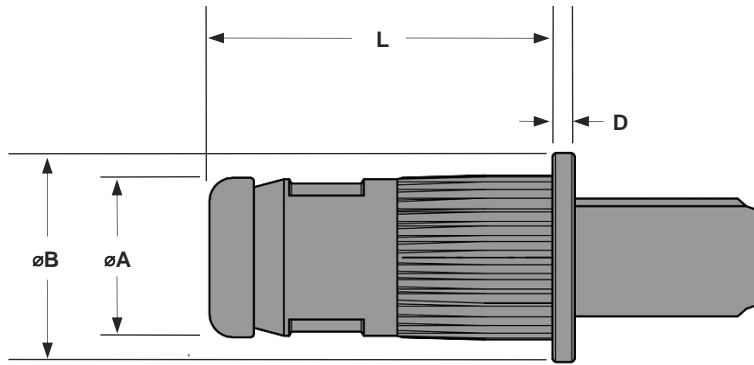

Part No.	Thread Size	Grip Range		Hole Size ±0.1	øA	øB	D	L	Thread Protrusion min.
		min.	max.						
GWST-MGBSM6-0560	M6	0.5	6.0	9.0	9.0	12.0	1.5	18.0	13.0
GWST-MGBSM8-0580	M8	0.5	8.0	11.0	11.0	14.0	1.5	20.0	15.5

Thread Size	Max. torque	Shear strength	Tensile strength
	Nm max.	kN	kN
M6	13.0	10.8	17.8
M8	26.0	18.4	27.8



### Can't find what you are looking for?

We can provide unique and customized solutions.  
Contact your nearest [Gripwell](#) team for assistance!